

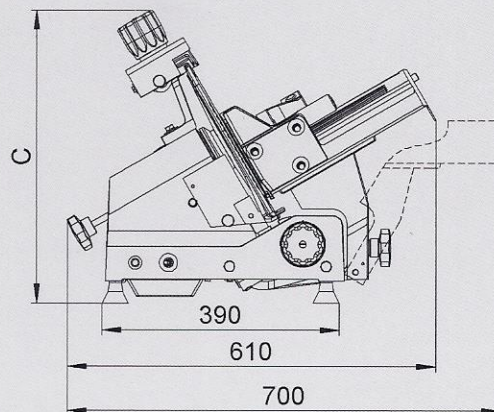

**USA 280-300-350**

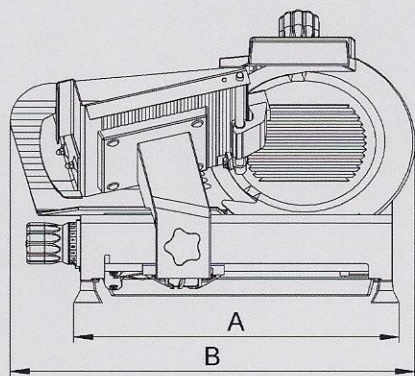





MOD.	A mm.	B mm.	C mm.	Cuchilla Blade Ø mm	Kg.	CV./HP.	Capacidad de corte Cutting capacity	
							Máx.  mm.	Máx. Ø mm.
USA - 280	535	625	435	275	30	0,33	270 x 145	185
USA - 300	535	630	440	292	32	0,33	270 x 155	200
USA - 350	535	670	470	320	34	0,33	285 x 180	220

- Rebanadora integrada de acero inoxidable 18/8 (Cromo/Níquel) en el carro y protector de cuchilla, con bastidor y tope (mesa) de aluminio anodizado.
- Cuchilla alemana de 65 HRc (dureza), baño de cromo duro de 14 µ (micras).
- Afilador integrado sistema automático.
- Motor con ventilación forzada, logrando una temperatura baja de funcionamiento, con 1/3 de H.P.
- Abatimiento del carro para su fácil limpieza.
- Aro protector cuchilla.
- Sistema de transmisión por banda, gruesa, ancha y estriada, diseño que le permite gran durabilidad.
- Protector de polvo y desperdicios en la base del tope (mesa).
- Espesor de corte: 0-16 mm.

- Slicer constructed of 18/8 stainless steel (Chrome/Nickel) in the carriage and blade guard hoop, with case and gauge plate (table) in anodized aluminium.
- Best quality German blade, hardened 65 HRc, and chrome plated 14 µ (micras).
- Automatic blade sharpener conveniently attached.
- Motor with cooling fan, maintaining a low operating temperature, with 1/3 H.P.
- Tilt-away product carriage swings clear for easy cleaning.
- Blade guard hoop.
- Belt drive transmission by a thick, wide and striated band with a design permitting a long durability.
- Dust and waste protector on the gauge plate (table) base.
- Cutting thickness: 0-16 mm.



Distribuidor / Distributor:



**MEXCUT CORPORACION S.A. DE C.V.**

Rancho Camichines, No. 25  
 COLONIA NUEVA ORIENTAL COAPA  
 14300 MEXICO D.F.

TEL.: (55) 56-79-89-89

FAX: (55) 56-79-65-40